

Pizza counters 2 Doors, 12 Drawers Refrigerated Counter with Show Case

ITEM # _____

MODEL # _____

NAME # _____

SIS # _____

AIA # _____



729603 (ARCSH2D12W)

2-door and 12-drawer
refrigerated counter with
showcase, glass protection

Short Form Specification

Item No. _____

Refrigerated counter with front and side panels, doors and drawers in 304 AISI stainless steel. Fitted with a granite worktop. Refrigerated section with 2 doors. Ambient section with 12 drawers suited for use with 1/1GN (not included). Built-in refrigeration unit. Ventilated/Static. Refrigerant R290. High-density expanded polyurethane foam, 90 mm in thickness, with cyclopentane injection. Digital control panel. Completely automatic defrosting and automatic evaporation of defrost water obtained by hot gas. Temperature range: -2+10°C. Suitable to operate in ambient temperatures up to +43°C. CFC and HCFC free. Feet in 304 AISI stainless steel, adjustable in height.

Show case in 304 AISI stainless steel with protective glass panels, sides and upper support shelf. It is designed for use with 1/4GN and 1/2GN containers (not included). Built-in refrigeration unit. Refrigerant R134a. Thermostatic temperature control. Temperature range: 0+10°C. IP20 protection.

Main Features

- Automatic evaporation of the defrosting water by hot gas on the top for energy saving.
- 1/2 or 1/3 drawers kits can be fitted on site as an alternative to the doors.
- Showcase suitable to accommodate ¼ and ½ GN trays available as accessories.
- Granite worktop for easy and fast dough spreading. 165mm high upstand to prevent foodstuff from accidentally falling from the sides and back during the preparation phase.
- Showcase and counter equipped with temperature setting, probe monitoring, HACCP alarms, service alarms and parameters customization as standard; remote HACCP monitoring available through an accessory kit.
- Neutral set of drawers on the right side allows dough storage both in GN 1/1 or 60x40cm trays.
- Tropicalized unit (43°C ambient temperature).
- CFC and HCFC free, highly ecological refrigerant type: R290 (ecological gas in foam: cyclopentane). Hydrocarbon refrigerant gas R290 for the lowest environmental impact (GWP=3), to reduce green house and ozone depletion effects.
- Refrigerated compartments can accommodate GN 1/1 grids or trays.
- Connectivity ready for real time access to connected appliances from remote and data monitoring (requires optional accessory).

Construction

- Developed and produced in ISO 9001 and ISO 14001 certified factory.
- Mounted on 150 mm adjustable feet.
- CFC and HCFC free (highly ecological refrigerant type: R290).
- Showcase with HCFC and CFC free refrigerant gas (R134a) and insulation.
- Showcase constructed in A304 stainless steel with rounded corners and tempered glass sides, backpanel and upper shelf.
- Showcase provided with power supply cable exit on left or back sides to suit all type of installations.
- Showcase with built-in, independent cooling unit with hidden evaporator designed to keep the food on covered trays between 0 °C and +10 °C at 43°C ambient temperature.
- Rounded internal corners. Drain and magnetic gaskets are removable without the use of tools and the condenser filter can be accessed quickly for ease of cleaning.
- Counter to feature built-in cooling unit with ventilated cavity and hidden evaporator foamed in the backside designed to work at +10°C even at 43°C ambient temperature.
- Counter constructed in A304 stainless steel with aluminum internal backpanel for low energy consumption, fast temperature recovery and optimal temperature uniformity.

Included Accessories

- 2 of 1/1GN gray rilsan grid PNC 881435

Optional Accessories

- Kit integrated HACCP for digital refrigerators (IR33) PNC 880252

APPROVAL: _____

- 1/1GN gray rilsan grid PNC 881435
- Polythene food container 400x600mm PNC 921854
- GN containers for refrigerated 2180mm show case - n. 7x1/4 + n. 2x1/2 h150mm PNC 921855



Front

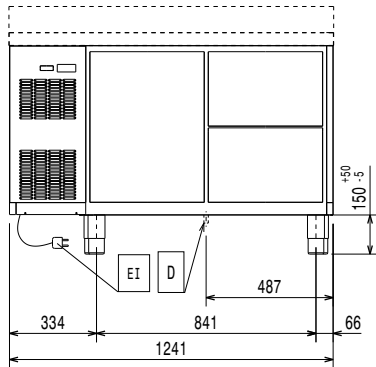

Side

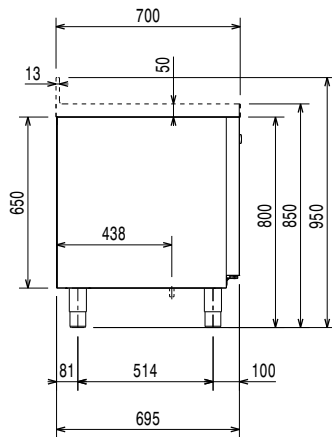

Top

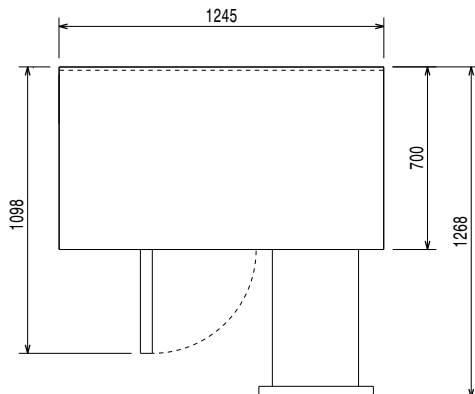

Key Information:

Door hinges:	729603 (ARCSH2D12W)	1 Left+1 Right
External dimensions, Width:	2180 mm	
External dimensions, Depth:	700 mm	
External dimensions, Depth with Doors Open:	1110 mm	
External dimensions, Height:	1501 mm	
Net weight:	330 kg	
Noise level:		
Worktop type:	Marble	
N° of drawers:	12	

Refrigeration Data

Control type:	Digital
Refrigerant type:	R290
Refrigeration power:	448 W
Refrigeration power at evaporation temperature:	-10 °C
Refrigerant weight:	50 g
Operating temperature min.:	0 °C
Operating temperature max.:	10 °C
Operating mode:	Ventilated/Static
N° defrost in 24 hrs:	every 6 hrs

Built-in Compressor and Refrigeration Unit